

Your new FIRMADOOR® has been designed to provide security, attractive appearance and smooth, low effort operation. Your door will not provide optimum performance unless it is installed correctly. Please follow the instructions carefully.

WARNING: No guarantee will be given or responsibility accepted by the manufacturers if the door is not installed as instructed. For satisfactory door operation please follow the instructions carefully.

WHAT YOU SHOULD LOOK AT BEFORE STARTING

OPENING REQUIREMENTS

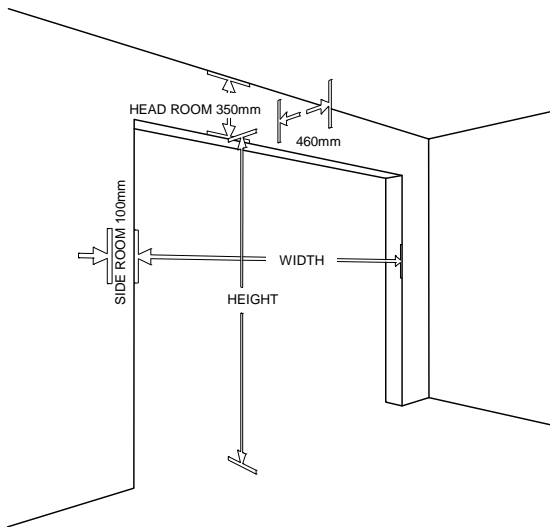

The door is designed to be mounted behind the opening, therefore you will need to measure and check:

OPENING WIDTH - As the door overlaps each side by 25 mm or more, the door should be 50 mm wider than the opening. A wider door can be fitted as long as additional side room and fixing is available. If the door is too narrow, the opening should be reduced by fitting jambs to the inside of the opening (Alternative Fixings No 1).

OPENING HEIGHT - The door will fit any opening height up to the marked door size (the guides can be cut to suit). After installation the walk-in clearance, under the door when installed, will be reduced by approximately 80 mm to allow access to the handle.

LEVEL AND PLUMB - The door must be installed in an absolutely level condition, if opening is not level and square, appearance and/or side- room requirements will be affected. Where jambs are out of plumb, extra side room or opening modifications may be required to allow the door guides to stand back from the opening edge. The floor should be level or recessed across the opening to avoid gaps.

STRUCTURAL SUITABILITY - Ensure the opening is strong enough to support the door.

SIDEROOM - A minimum of 75 mm (100 mm desirable) of sideroom is required behind the opening and should extend above the head to allow for bracket fixing. Sideroom on one side of 115 mm is required if a Firmamatic® garage door opener is to be fitted now or in the future.

OBSTRUCTIONS - Ensure that the surface where the door will be fitted is flush and smooth, and the area behind the opening is free from any protrusions.

HEADROOM - See diagram below. If the door is installed lower into the opening than shown, additional loss of walk-in clearance will result. The fitting of a false head may also be necessary, in order to improve the external appearance (See Alternative Fixings)

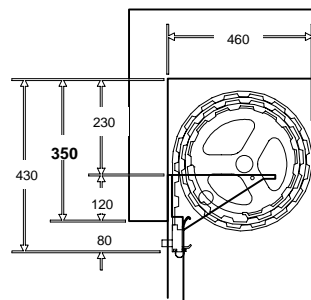

NORMAL HEADROOM
UP TO 2200 mm HIGH

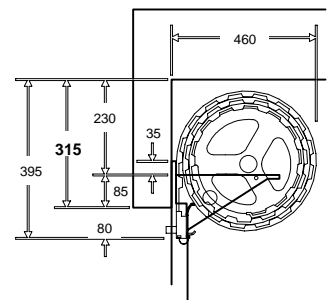

RESTRICTED HEADROOM
UP TO 2200 mm HIGH

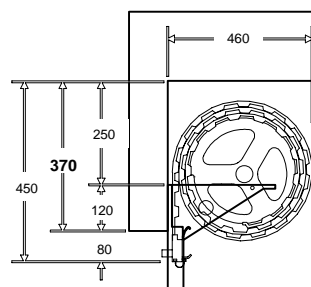

NORMAL HEADROOM
OVER 2200 mm HIGH

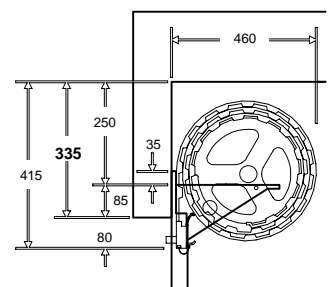

RESTRICTED HEADROOM
OVER 2200 mm HIGH

FIXINGS

Coach screws are supplied with the door for fitting to timber.

Correct and safe fastening to other materials may require different fasteners.

The installer must select and use fasteners appropriate to the material into which they are being fixed.

NOTE - It is the installer's responsibility to ensure that the fixing methods are sound.

TOOLS REQUIRED

Tools required to install the door. You will also need assistance to help you lift the door up safely and carry out some other steps.

- a power drill & bits
- a file
- a hacksaw
- 2 stepladders
- adhesive tape
- marking pen
- tape measure
- phillips head screwdriver
- a socket set
- spirit level
- Stanley knife
- water level (10 mm diameter clear tube by 6 m long)
- 450 mm (18") Pipe Wrench

THE DOOR

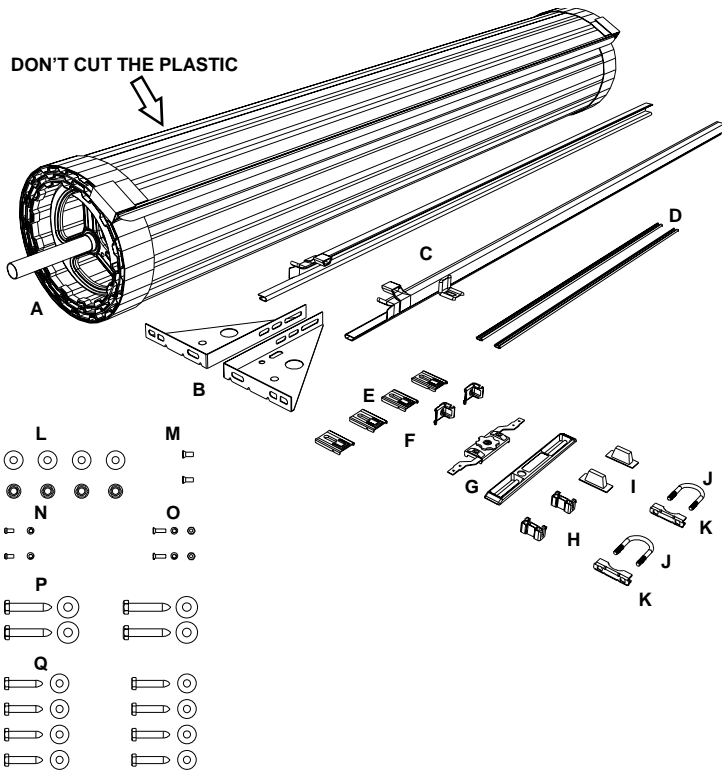

PLEASE NOTE-

1. **Do not cut the plastic wrap that holds the door in a roll (wait until step 5)**
2. Remove all parts from each end of the door roll
3. Handle the door with care to avoid curtain damage.
4. Ensure you have required tools plus ladders.
5. Follow the instructions carefully.

PARTS CHECK LIST -

- | | | | |
|----|------|---|---|
| A. | 1 | - | rolled plastic wrapped door |
| B. | 2 | - | "A" style brackets, left and right handed |
| C. | 2 | - | door guides, left and right handed |
| D. | 2 | - | steel locking bars |
| | 1 | - | small parts bag containing |
| E. | 4-10 | - | guide clips |
| F. | 2 | - | metal stops |
| G. | 1 | - | faceplate and lock assembly |
| | 2 | - | keys |
| H. | 2 | - | locking bar retainer |
| I. | 2 | - | locking bar covers |
| J. | 2 | - | "U" Bolts |
| K. | 2 | - | axle/bracket saddles |
| L. | 4 | - | 8 mm nuts and washer for "U" bolts |
| M. | 2 | - | Counter sunk screws for handle |
| N. | 2 | - | 7 mm x 4 mm mushroom head screws |
| O. | 2 | - | 4 mm x 6 mm locking bar screws |
| P. | 4 | - | 50 mm x 10 mm coach screws and washers |
| Q. | 8-12 | - | 40 mm x 8 mm coach screws and washers |

INSTALLING YOUR FIRMADOOR® ROLLING GARAGE DOOR

STEP 1. FIRST BRACKET

- a) Measure the door curtain width and mark where edge of the curtain will be allowing for overlap on each side of the opening.
- b) Add clearance of 10 to 75 mm from edge of curtain to inside edge of bracket to determine positioning of the bracket.
- c) **Normal Headroom** (350 mm for doors up to 2200 mm high, 370 mm for doors over 2200 mm high). Measure up 120 mm from underside of the head. If the head is not level, measure up from the lowest side first.
Restricted Headroom (315 mm for doors up to 2200 mm high, 335 mm for doors over 2200 mm high). Measure down 230 mm (or 250 mm if door is over 2200 mm high) from roof or lowest obstruction to the top of the bracket. (Bracket should be between 85 mm and 100 mm up from the lintel).
If less headroom than shown above or no headroom is available, follow the restricted headroom instructions and for appearance purposes fit a false head if necessary.
- d) Mark two hole positions using top and bottom slots of the bracket.
- e) Drill both holes, then attach bracket using the 50 mm x 10 mm coach screws and washers supplied (or masonry anchors if fixing to brickwork).

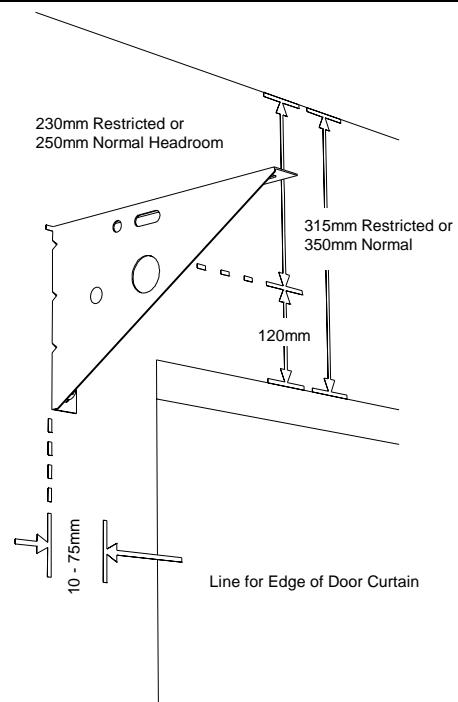

STEP 2. SECOND BRACKET

- a) Using a water level mark the position for the second bracket.

NOTE:

The brackets must be perfectly level for the door to operate correctly.

- b) Re-check levels then drill and fix as with first bracket.

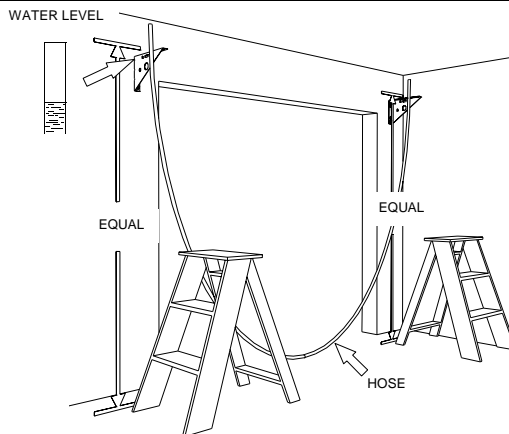

STEP 3. PLACE DOOR ON BRACKETS

- a) Check the axle length and cut if side room is limited. Before cutting, make sure the floating axle is free and centred. Centre will be found by rotating the axle a quarter turn in either direction then releasing. With centre found, make a clear mark on the axle against the hub for later reference.
- b) Lift door onto the brackets (the right way round so that the door will roll down from the front of the opening). Loosely fit the "U" bolts, saddles, washers and nuts to the brackets in position shown. (Do not tighten until Step 4, c.)

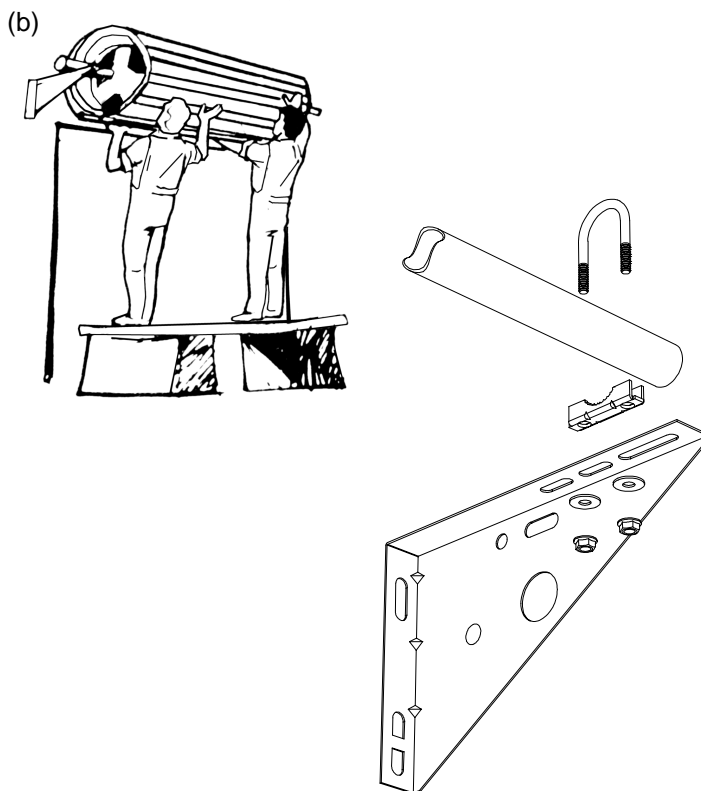

(a)

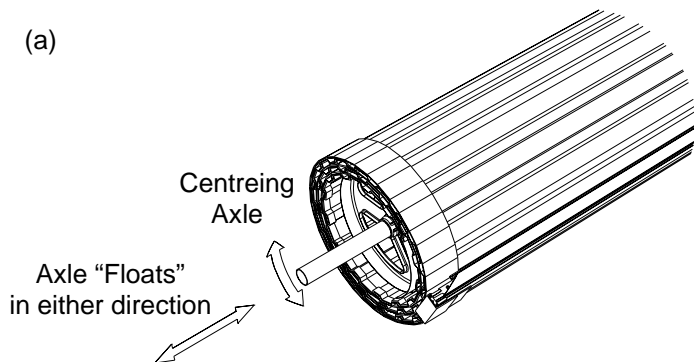

STEP 4. POSITION DOOR

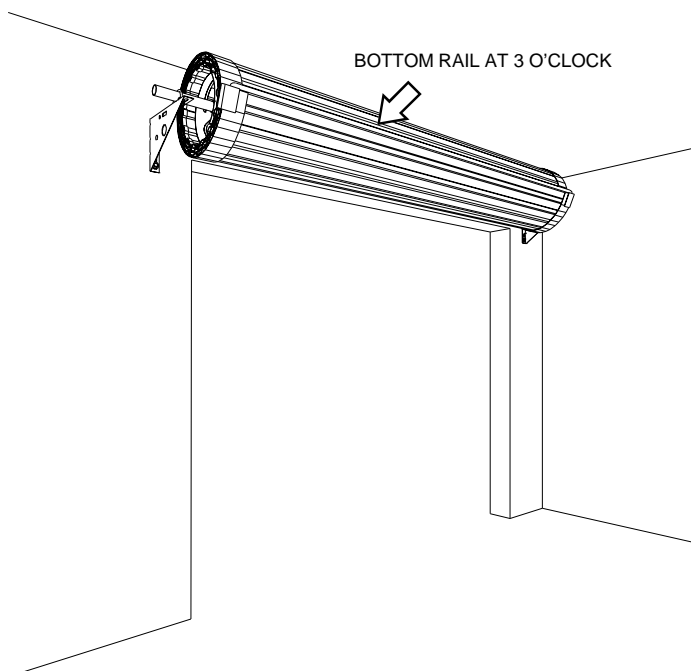

- a) Centre the door with the opening, while ensuring the floating axle is also centred with the door.

Do this by lining up previous marks with the hub, then lift both the axle and the door together until it is centred with the opening.

- b) Rotate the curtain and axle so that the bottom rail of the door is positioned as shown (three o'clock).
- c) Push the axle forward in the slots (toward the opening) and tighten the nuts firmly without over-tightening. (10 Newton metres or 6.6 feet/pounds torque reading).

STEP 5. TENSION THE SPRINGS

FIRST PREPARE A SOFTWOOD CHOCK, ABOUT 400 mm LONG.

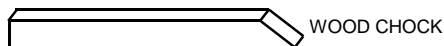

THEN

Ensure that bottom rail is at the 3 O'clock position as shown in Step 4 - if not, refer to Step 4.

- a) Ensure both "U"bolts are tightened, then -
 - ❶ Rotate the door 1 1/2 turns in a forward direction to apply tension. See arrow in Fig (b).
 - ❷ Hold the door firmly, **NOW** cut the plastic wrap along the bottom rail (taking care not to damage door surface or weather seal)
- b) Pull the curtain down slowly and carefully position the wooden chock (or other appropriate stop) as shown in Fig (c). Take care not to damage door surface.

The chock will help hold the door until the guides and stops are fitted.

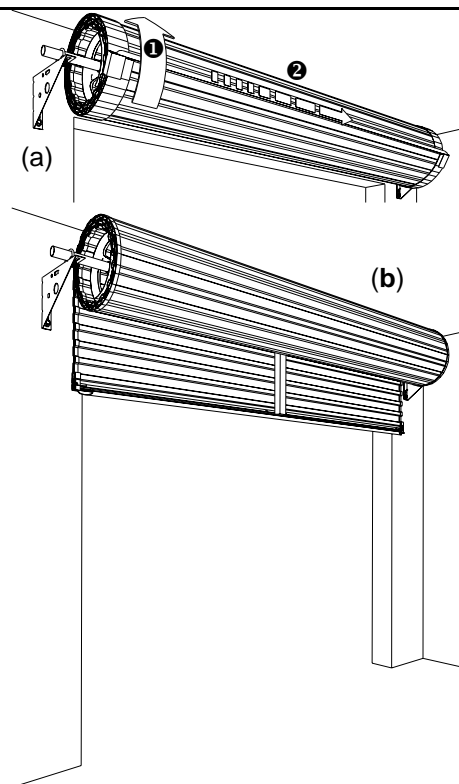

STEP 6. STOP

To attach metal stops to bottom rail of door

- a) Hook stop behind lip in rail, as shown.
- b) Secure from underneath the rail with screws supplied. You may need to trim weather seal.

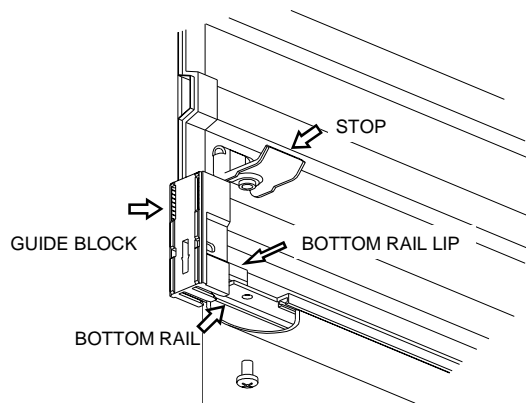

STEP 7. GUIDES

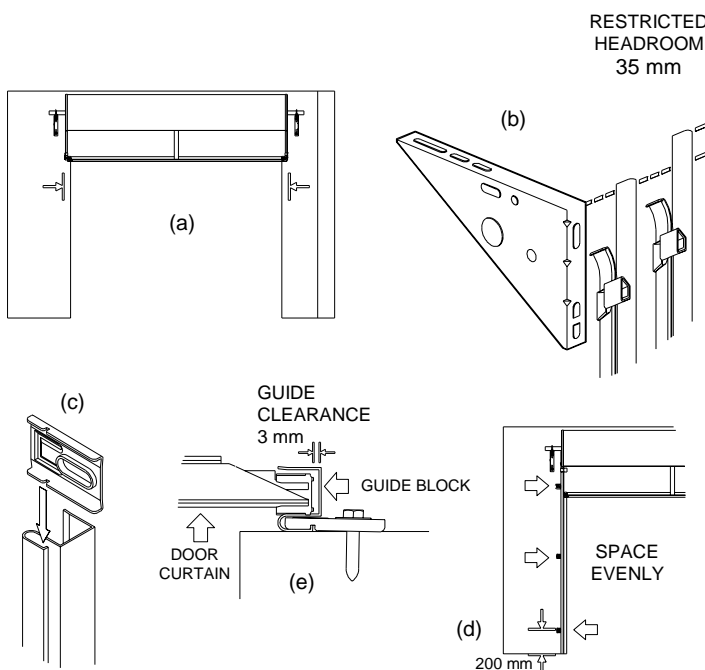

- a) Check that curtain overlaps equally on both sides.
- b) Check that guides are the correct length, that is, level with the brackets (or in the restricted headroom position are 35 mm maximum above bracket).
- c) Slide half the number of guide clips into each guide.
- d) Position the bottom clip 200 mm from the floor with the rest evenly spaced along the guide. (Hint: to prevent clips from sliding down the guide, temporarily secure them with adhesive tape.) Now position one guide over the edge of the door curtain.
- e) Mark and drill the top fixed guide clip and secure using a 40 mm x 8 mm coach screw and washer, allowing 3 mm clearance between the inside of the guide and plastic guide block.
- f) Ensuring guide is plumb, drill and fix remaining clips. (Note: if securing to uneven brickwork, packers may be required behind clips, to prevent them twisting out of square ; also ensure that clips are positioned on secure bricks).
- g) With the top of the 2nd guide level with the first, repeat (e) and (f).
- h) Remove the chock and slowly lower the door removing plastic wrap as you pull door down, reposition the guides as necessary to allow smooth and even operation with 3 mm clearance throughout.
- i) Ensure door curtain enters guides smoothly.

STEP 8. CENTRE LIFT LOCK

- Raise the curtain until the lock corrugation is visible above the door guides
- Install locking bar retainer in line with lock corrugation by pushing retainer towards door edge, sliding the legs under the Nylofelt® and hooking them over the curtain edge (it is easier to hook legs one at a time). Ensure lock bar retainers sit squarely on door curtain. See Fig (b).
- Fit faceplate to outside of door where the hook will latch onto curtain edge, then slide faceplate as far to the right as far as possible. Use adhesive tape on outside to hold in position.
- Attach the lock body to the faceplate from the inside, using the mounting screws and washers. Do not over tighten the screws. See Fig (d).
- With the door in the closed position slide the end of the locking bars through the locking bar retainers, and while holding the bars level mark the side of the guides.
- Drill and file out a rectangular slot no longer than 25 mm and no wider than 10 mm. Ensure top of slot remains in line with top of locking bar.
- Slide bars through the guide slot, then back onto lock arms. Screw on securely using the 4 mm x 6 mm screws supplied. Ensure that locking bars do not protrude more than 20 mm beyond guide when engaged in locked position.
- Ensure a clean and dry guide surface. Wipe guide with clean rag.
- Peel off lining from lock bar cover and position over hole. Check that the movement of the locking bar is free.

Note: the fitting of the lock bar covers is important to prevent possible finger entrapment - particularly important when the door is fitted with an automatic garage door opener.

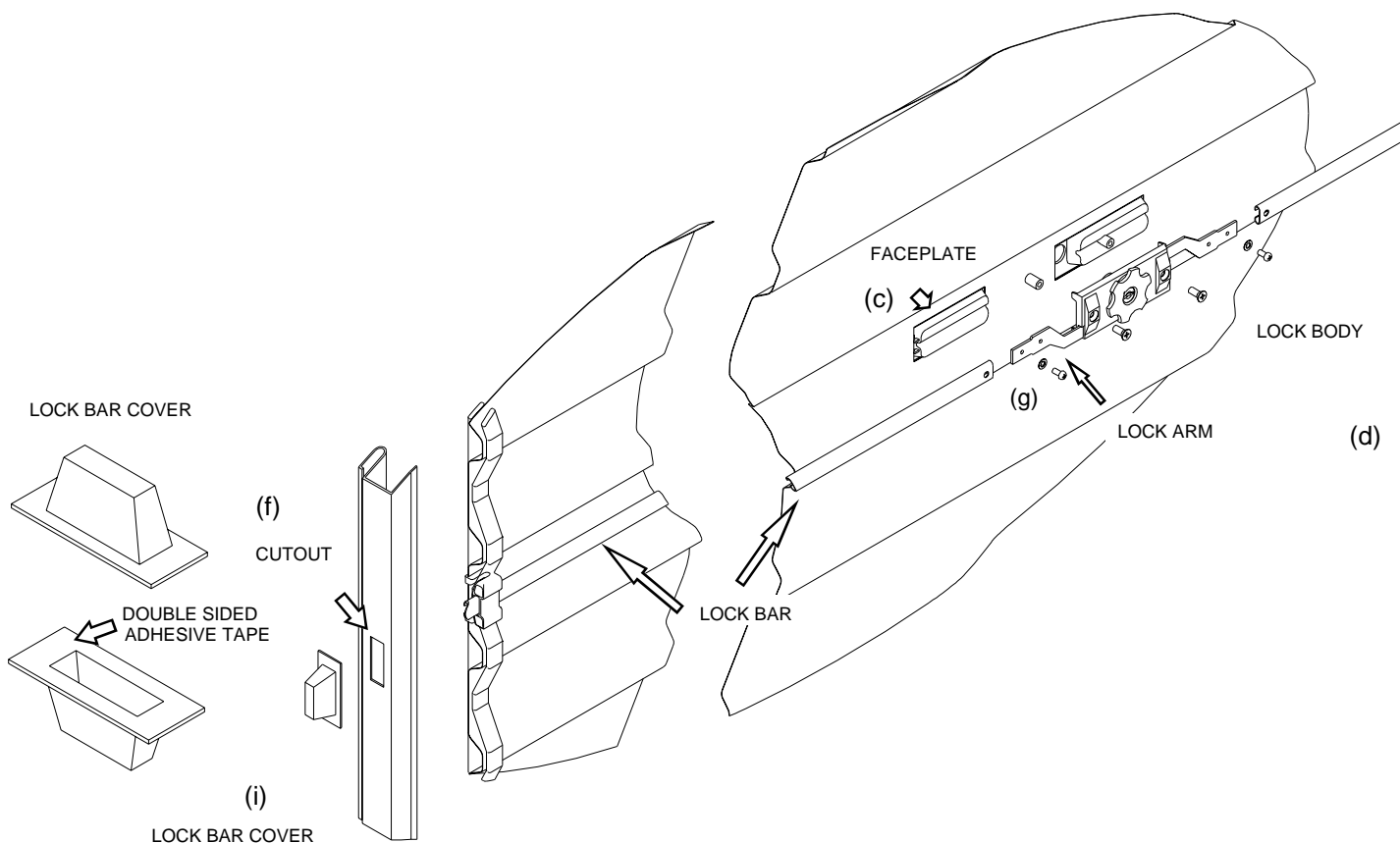
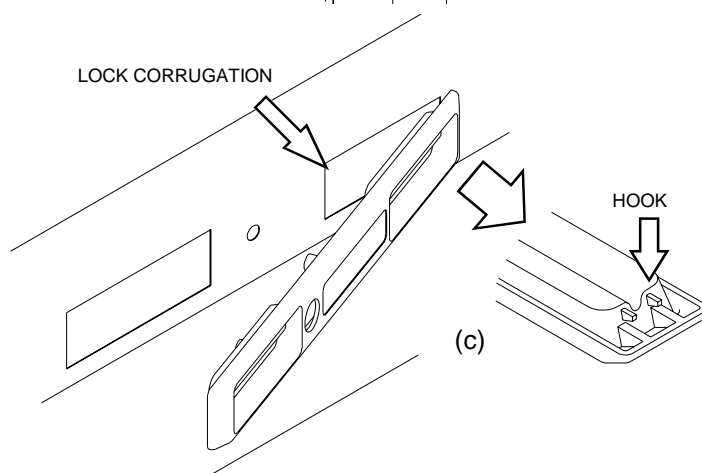
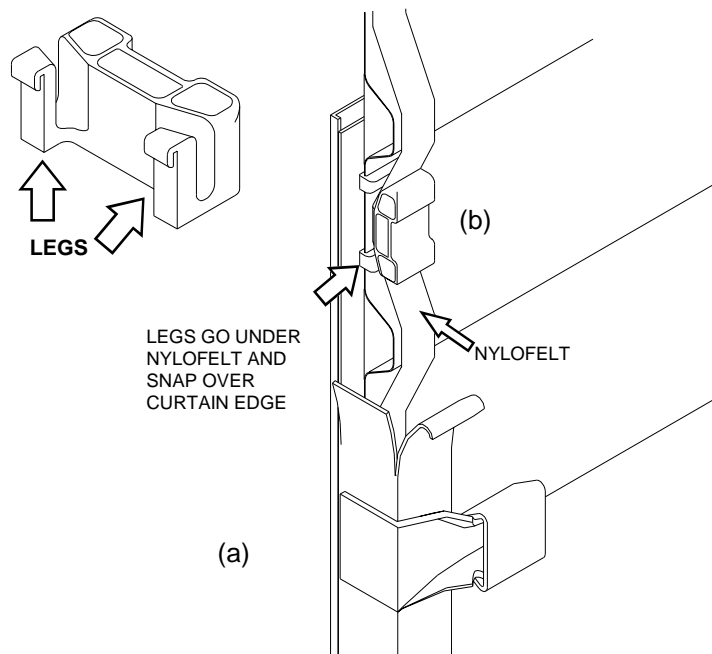

STEP 10. FINAL ADJUSTMENT

1. If the door is hard to operate in **ANY DIRECTION** check that the door is not jamming in the guides.

Check:

- a) the guide clearances.
- b) that guides are plumb.
- c) that the guide surfaces are clean and free from oil.
- d) that locking bars are the correct length
- e) weather seal is correct length

2. If the door is hard to operate in **ONE DIRECTION**, the spring tension requires adjustment. See Step 12
 - a) if the door is hard to lift, but tends to drop, then increase the spring tension.
 - b) if the door is hard to close, but tends to rise, then decrease the spring tension.

3. If the door rolls up crooked as shown below then:

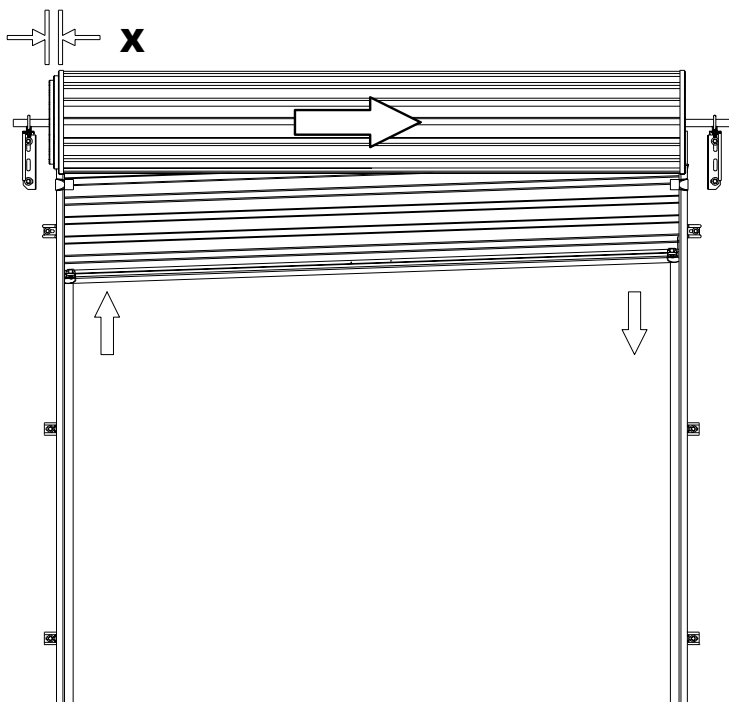

Check:

- a) Brackets are level, refer to Step 2.
- b) Axle is centralised.
- c) Guides are plumb, refer to Step 7.

To centralise the axle:

Note: these instructions are for the example illustrated - the axle needs moving to the right (to move left they would be vice versa)

Pressed metal "A" style bracket:

To move the axle to the right, loosen left hand "U" bolt and push axle to the right by distance "X" (see diagram) and **re-tighten** "U" bolt. Then go to the other end of the door and loosen "U" bolt, allow bracket to return to its natural position (should move towards door) then **re-tighten** "U" bolt.

Fabricated (welded) bracket:

With the door rolled up loosen one "U" bolt, then go to the other end of the door and with a firm hold on the axle, with a pipe wrench, loosen the second "U" bolt and move the axle to the right (the direction of the arrow in diagram). Move the door distance "X" in diagram. **Re-tighten** one of the "U" bolts before releasing pipe wrench then **re-tighten** the other "U" bolt.

If the door is stiff to work or rattles over lead-in on top of guide, then refer to Step 7.

TO ADJUST SPRING TENSION (FOLLOW CAREFULLY)

1. With the door rolled up tie two ropes around the door roll approximately 300 mm from each end, as a safety precaution.
2. With a man at each end of the door, hold the axle firmly with a large pipe wrench (Stillson) at least 450 mm long.
3. Loosen the "U" bolt nuts at both ends and **KEEP A FIRM GRIP ON WRENCH.**
4. Rotate the axle in the required direction (see diagram).
5. Re-tighten the "U" bolts **BEFORE** releasing pipe wrench.
6. Test and repeat if further adjustment is necessary.

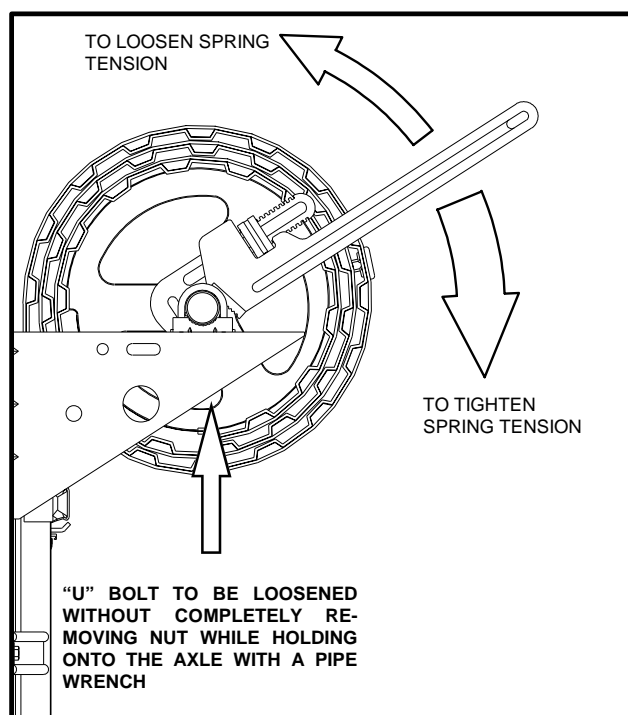

FIXING ALTERNATIVES

1. Alternative Guide Fitting

BRICK GARAGE

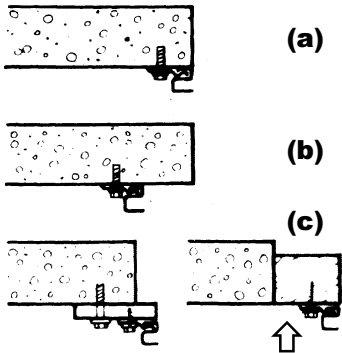

TIMBER GARAGE

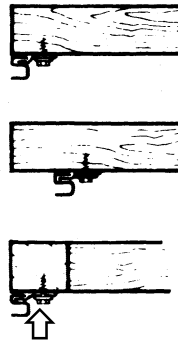

REDUCE WIDTH WITH SUITABLE TIMBER

- (a) Exact opening size: Door overlaps 25 mm each side.
- (b) Door is too wide: The guides can be set back inside from the opening edge.
- (c) Door is too narrow: Reduce opening with quad or suitable timber ensuring that back of opening surface remains flush.

2. Alternative Headroom Fitting: Appearance Improvement

If headroom is less than 250 mm, a false head should be fitted to improve the external appearance of garage opening. Note that the false head must not be installed too close to the curtain face.

FIRMADOOR® Head Infill Panels are available to match or contrast with your door(s).

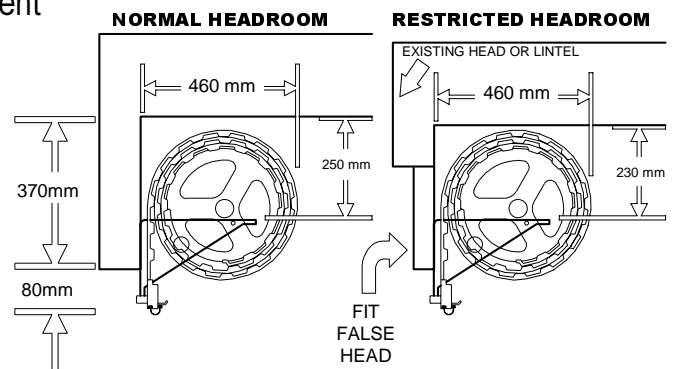

3. Alternative Bracket Fitting

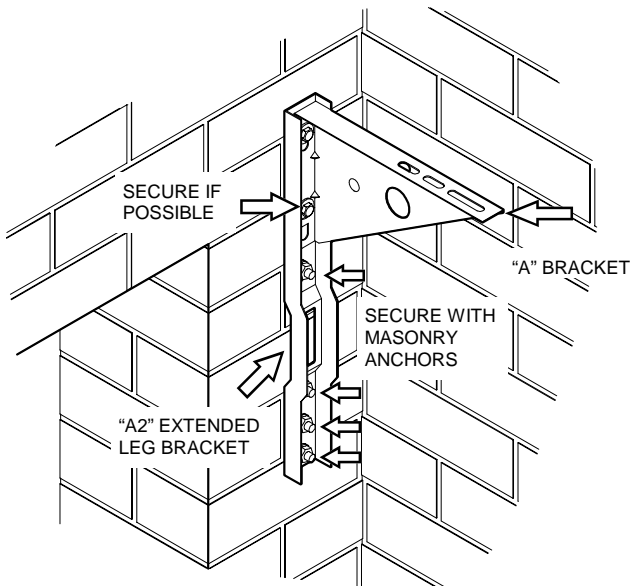

An "A2" extended leg bracket should be used in conjunction with the standard "A" style bracket - under the following circumstances:

- a) If brickwork is old, or in any way suspect.
- b) If floater bricks are present, but sound fixing lower down the brickwork is available.
- c) When fixing to honeycomb or semi-hollow bricks.
- d) Where RSJ interferes with "A" bracket.

NOTE: Where old brickwork with lime mortar is encountered, or any doubt exists as to the holding power of the masonry work, a timber frame, which continues above the head for bracket fixing, should be fitted on the back surface of the opening.

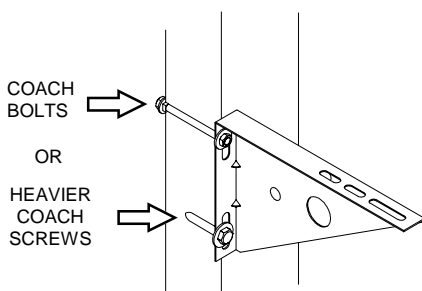

When fixing brackets to timber, the heavier coach screws supplied are usually adequate. In some cases, especially where timber is very soft, old or insecure, coach bolts should be used.

AFTER INSTALLATION

GENERAL CARE OF YOUR FIRMADOOR®

BHP COLORBOND® FINISH - Your Colorbond® door has been pre-painted with a silicone modified polyester formulation, which is one of the best paint films commercially available today. However, all exposed surfaces require some attention to guard against the premature onset of corrosion and any other harmful atmospheric effects. In our atmosphere there are harmful deposits that gather on the door surface and if not removed regularly, will seriously affect the appearance and life of the door. Washing of the door with clean water and a cloth every 14 days is recommended – particular care should be taken to clean areas of the door not normally washed by rain, including the top of the door roll inside the garage.

NOTE: In locations where there is likely to be salt in the air or industrial fallout is severe, more frequent washing is advisable and additional protection of the surface may be required. Touch-up paint, if required, is available from your FIRMADOOR® dealer.

ZINC COATED STEEL FINISH - Painting of BHP zinc coated steel requires special attention. If you wish to paint this surface we recommend you seek advice from your nearest paint specialist or hardware store or by contacting BHP Sheet and Coil Division for expert advice.

IMPORTANT: DO NOT paint inside the guide tracks or on the Nylofelt® running strips – remove paint immediately if it gets on these areas.

LOCK - Your lock does not require special maintenance, however, if the keyway becomes stiff, the application of powdered graphite is recommended – do not grease or oil the lock. The plastic section of the faceplate should be washed with soapy water and rinsed well. Strong solvents, such as acetone, should not be used – these will damage the surface. **WARNING!** Do not disassemble the lock mechanism and do not allow paint to enter the lock keyway.

When opening the door, always make sure the key is withdrawn from the lock – if this is not done, the lock mechanism could be damaged and the key bent or broken.

We suggest you record your full Key letter and Number on the front of this card and if replacement keys are required they can be obtained from the FIRMADOOR® office in each State, simply by quoting this number. If the keys have been lost and the number not recorded, it can be found stamped into the locking arm at the back of the mechanism.

NYLOFELT® - On no account should you use grease or oil in the door guides or on the Nylofelt® running strips – the grease or oil will clog the Nylofelt® and spoil the operation of the door. An occasional wipe with a cloth dampened with mineral turps or methylated spirits, down the inside of each guide, is very beneficial in removing any trace of grease or dirt. After the guides have been cleaned, a silicon spray may be used in the guides.

(Note: WD40 or similar oil based sprays are not silicon and should not be used)

Care should be taken not to damage the Nylofelt®, however, if Nylofelt® is cut or damaged, a lighted match should be used to quickly seal the ends of the nylon braiding, so as to stop any further deterioration.

REGULAR MAINTENANCE REQUIRED

FIRMADOOR® Australia recommends that you check the operation of your FIRMADOOR® Rolling Garage Door at least every six months (more regularly in extreme environments or frequent use). The effort required to manually open and to manually close the door should be about the same (if door has an automatic opener, put into manual mode before testing door). If the door is difficult to operate in either direction (up or down) then check:

- 1) that the Nylofelt® running strips on each side of the door have not slipped from the edge and are jamming the door.
- 2) that the door is running correctly in the guides and the guides are straight and perpendicular.
- 3) that the inside surfaces of the guides are clean and free of obstructions. (see paragraph on care of Nylofelt®)

If you have checked these (and corrected where necessary) and the door is still difficult to operate, then your door will need a service to adjust the spring tension and possibly other operational parts of the door. This service should only be carried out by an experienced door technician, using the correct tools.

If you have an automatic opener fitted to your door, it is particularly important that you ensure the optimum operation of the door, otherwise you may reduce the effective life of the opener.

To keep your door running well, it is recommended that your door be serviced, by an experienced door technician, every two (2) years (more regularly in extreme environments or frequent use), or earlier if required.

SPRING TENSION

It is natural for springs to lose tension over time. When spring tension is adjusted or when your door is first installed it is usual to apply a little more tension than is required for balanced operation, to allow for the normal “settling in” of the springs.

DISTRIBUTED BY:

NSW Office:	FIRMADOOR Australia, 34 Marigold Street, Revesby 2212.	Phone: (02) 9722 5555
QLD Office:	FIRMADOOR Australia, 37-47 Cobalt Street, Carole Park 4300.	Phone: (07) 3271 7000
VIC Office:	FIRMADOOR Australia, 147-153 Caterbury Road, Kilsyth 3137.	Phone: (03) 9237 7766
SA Office:	FIRMADOOR Australia, 23 Frederick Road, Royal Park 5014.	Phone: (08) 8447 4747
WA Office:	FIRMADOOR Australia, 225 Balcatta Road, Balcatta 6021.	Phone: (08) 9344 3333

OBTAINABLE FROM:



“Colorbond” is a registered trademark of BHP Steel Pty Ltd.

The “FIRMADOOR”, “FIRMATIC” and “Nylofelt” are registered trademarks of Evans Deakin Industries Limited.

FIRMADOOR™
GARAGE DOORS